



PARTS CAP



Eberspächer



**DON'T LET
WINTER
STOP YOU**

CRITICAL PREHEATING FROM EBERSPAECHER

Don't let winter conditions keep you off the road. Trust Eberspaecher heaters to keep you warm and keep your engine running smoothly.

Eberspaecher's Hydronic S3 coolant heater, offers engine and supplemental cab preheating while the Airtronic D2 forced air heater, warms the cab instantly. Reduce your fuel costs, emissions and engine wear by installing an Eberspaecher heater.

- reliable starts
- engine off, instant heat & defrost
- 17,500 BTu (HS3)

www.eberspaecher-na.com
800-387-4800



A WORLD OF COMFORT  **Eberspächer**

www.eberspaecher-na.com  

Eberspaecher Climate Control Systems

Eberspaecher offers a comprehensive range of idle-free fuel-operated air and coolant pre-heaters.



AIRTRONIC PRODUCT BROCHURE (https://www.eberspaecher-na.com/fileadmin/data/countrysites/EB_Kanada/pdf/EB_Airtronic_D2_D4_D5_WEB_READY_01_26_15.pdf)

Hydronic S3 Product Brochure (http://www.eberspaecher-na.com/fileadmin/data/countrysites/EB_Kanada/pdf/eberspaecher-techposter-hydronic-S3-en.pdf)

Warranty Registration Form (<http://www.eberspaecher-na.com/warranty/warranty-registration-form.html>)

Product Highlights

Eberspaecher NA offers a comprehensive range of idle-free fuel-operated air & coolant pre-heaters.
By utilizing these pre-heaters, you can expect:

- Reliable warm-engine starts
- Engine-off instant heat & defrost within a safe environment
- Improved cab comfort
- Preheat of critical fluids
- Increased DPF performance
- Decreased fuel costs
- Lower emissions
- Reduced engine wear
- Extended work seasons
- Increased productivity
- Reduced carbon footprint



Top Movers - Hydronic S3 (coolant pre-heat) & Airtronic (air heat)



Espar Part number	Description
20.2820.69.0263.0Z	AIRTRONIC D2 W/ DIGI MAX CONTROLLER
20.2821.13.0423.0Z	AIRTRONIC D4 W/ DIGI MAX CONTROLLER
25.2069.05.0000.0Z	Airtronic D2 Base Heater
25.2826.52.0525.0Z	HS3 D5E HEATER ASMBLY 12V W/P.U.P NO E.S
25.2826.52.0540.0Z	HYDRONIC III D5E Right BOXED KIT W Easy Start
25.2826.52.0545.0Z	HYDRONIC III D5E Left BOXED KIT W Easy Start
20.2812.15.2065.0Z	D2/HIII D5E Combo Digi-Max / W Easy Start
20.2812.15.2066.0Z	D2/HIII Right BOXED D5E Combo Digi-Max / W Easy Start
20.2812.15.2067.0Z	D2/HIII Left BOXED D5E Combo Digi-Max / W Easy Start
22.1550.89.0000.0Z	EasyScan Diagnostic Tool

Factors Affecting Our Industry

Industry Globalization	Commonly accepted products in Europe are striking the North American market place. Diesel-fired heaters are found in almost 80% of the trucks in Europe
Fuel Prices	Fuel price escalation accelerates the payback formulas for investing in idling alternative technology.
Fuel Data	Reliable data from electronic engines now produces industry benchmarks, highlighting the inefficiencies of idling for sleeper comfort.
The EPA	Environmental Protection Agency campaigns promote awareness of idling alternative products aimed at reducing reliance on fuel and protecting air quality.
Legislation	Idling legislation continues to expand and is increasingly being enforced.
Warranty	Engine manufacturers now build warranty limitations based on operating hours and idling wear factors.
The Human Factor	Demand for improved driver morale means attentions must be paid to driver comfort, sleep and air quality.

General Heater Information

Hydronic S3



Coolant Heaters: Structure & Function

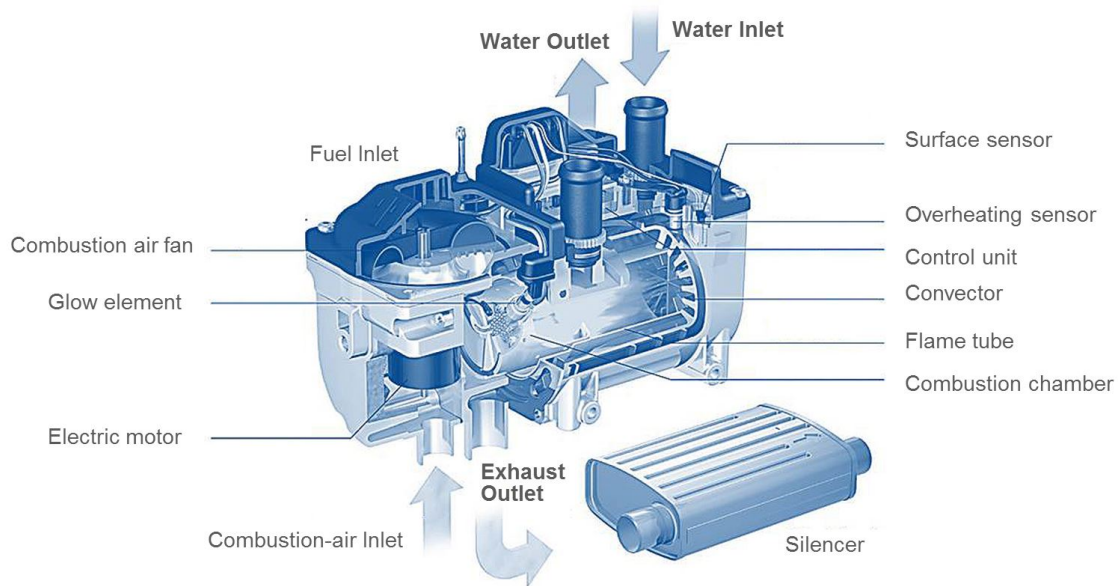

The coolant heater, with a minimal amp draw and very low fuel use, is connected to the engine's cooling system. The heater is ignited via a glow pin; a flame is established and the glow pin shuts off. The heater maintains this flame until it is manually or automatically shut off. An integrated water pump circulates the water over the heat exchanger and heats the coolant. The hot coolant then flows through the engine block. All major components, such as the electronic control unit, water/fuel pumps and safety sensors, are integrated into the system to minimize size and installation time.

Airtronic

Air Heaters: Structure and Function

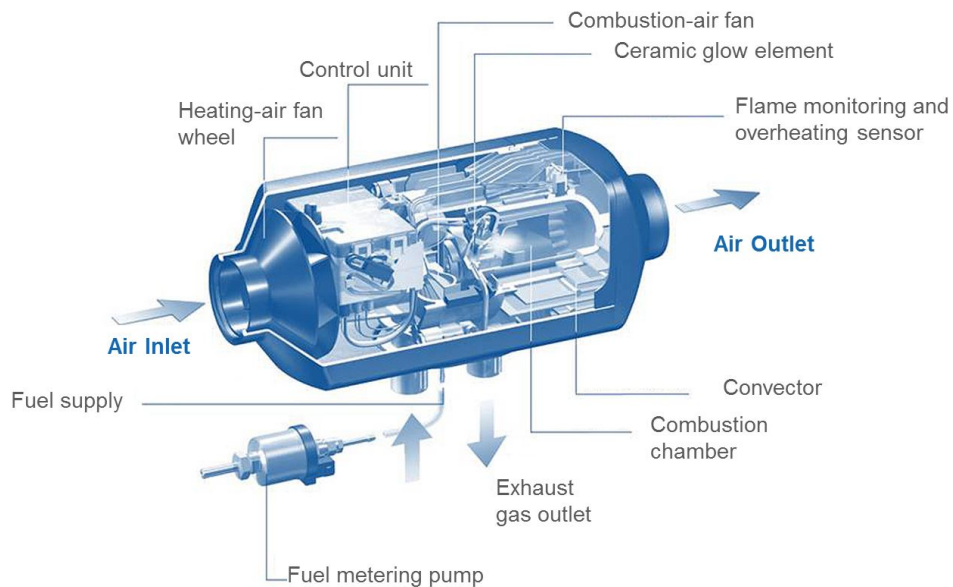

When the air heater is turned on (by the switch, thermostat or timer), a control unit signals the blower motor to draw combustion air into the heat exchanger. At the same time, fuel is drawn from the truck's fuel tank by the heater's fuel pump and mixed with the air. As a glow pin ignites the fuel / air mixture, a controlled flame is established inside the sealed heat exchanger. Combustion gasses pass safely through the exhaust and into the atmosphere. Clean air is drawn over the walls of the heat exchanger and



Warranty Information

Eberspächer's warranty policy for Airtronic D2/D4 and Hydronic S3 covers parts and labor for 2 years on new trucks and 2 years on aftermarket, after the product has been purchased by the end user. Please refer to the Eberspächer Warranty Policy Manual, available under Warranty at www.eberspaecher-na.com/warranty (<http://www.eberspaecher-na.com/warranty>) .

Last updated: Thursday, 09 January 2020 12:42 PM

[^Back to Top](#)

Copyright © Daimler Truck North America LLC. [Privacy Statement, Legal Notices and Terms \(https://daimler-trucksnorthamerica.com/privacy-policy\)](https://daimler-trucksnorthamerica.com/privacy-policy).

All rights reserved. Daimler Truck North America LLC is a [Daimler \(http://www.daimler.com/\)](http://www.daimler.com/) company.

